

SEWING DATE TRAVELER

Designed by Cynthia Frenette
www.cynthiafrenette.com

Featuring
Sewing Studio ♥cynthiafrenette



Finished project measures: 12" x 9-1/2" x 6-1/2"







Pattern Level: Experienced Intermediate

"I know the ropes and would like to test my skills!"

ROBERT KAUFMAN
F A B R I C S

Fabric and Supplies Needed

Fabric amounts based on yardage that is 40" wide.

Color	Fabric	Name/SKU	Yardage	Color	Fabric	Name/SKU	Yardage
	A	E064-1019 BLACK *for exterior	3/4 yard		E	ACK-15854-218 AVOCADO *for inside pockets	1/4 yard or 1 FQ
	B	ACK-15852-5 YELLOW *for lining	3/4 yard		F	ACK-15853-12 GREY *for zipper pouch divider	1/4 yard or 1 FQ
	C	K001-359 PEPPER *for binding and pouch/pocket lining	3/4 yard		G	ACK-15855-1 WHITE *for handles	1/4 yard or 1 FQ
	D	ACK-15851-218 AVOCADO *for outside pockets	1/4 yard or 1 FQ	Copyright 2015, Robert Kaufman For individual use only - Not for resale You will also need: 2 yards Pellon 65 or similar heavy weight interfacing 12" Closed End Zipper Spray Basting (Optional)			

Notes Before You Begin

- Read through all of the instructions before beginning.
- All of the seam allowances are 1/4" unless otherwise noted.
- Press seam allowances open unless otherwise noted.
- Width of fabric (WOF) is equal to at least 42" wide.
- Right sides together has been abbreviated to RST.
- Remember to measure twice and cut once!

Cutting Instructions

From **Fabric A**, cut:
two 24" x 14" for tote body

From **Fabric B**, cut:
two 22-1/2" x 12-1/2" for tote body lining

From **Fabric C**, cut:
four 13" x 6-1/2" for outside and inside pocket linings
two 12-1/2" x 6" for zipper pouch divider lining
two 2-1/4" x WOF strips for bindings
two 1" x 2" for zipper tabs

From **Fabric D**, cut:
two 13" x 5-1/2" for outside pockets

From **Fabric E**, cut:
two 13" x 5-1/2" for inside pockets

From **Fabric F**, cut:
two 12-1/2" x 6" for zipper pouch divider

From **Fabric G**, cut:
two 6" x 14-1/2" for handles

From **Interfacing**, cut:
two 1-1/4" x 14" for handles
four 12" x 5-1/2" for outside and inside pockets
two 24" x 14" for tote body
two 12-1/2" x 5-1/2" for zipper pouch divider

Make the Zipper Pouch Tote Divider

Prepare Zipper

Zipper tabs:

Fold each 1"x 2" tab in half matching short ends, with wrong sides together, so the tabs measure 1"x1", and press, forming a crease line. Using a cutting mat or ruler, align the tabs as shown, moving the zipper pull over towards the center of the zipper and away from the tab. Note the measurement markings on the diagram for proper placement of the zipper tabs.

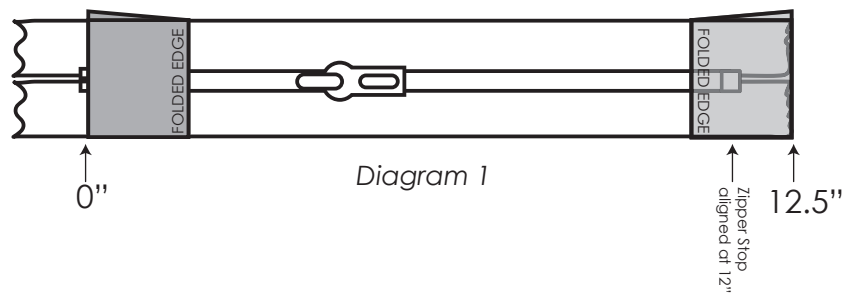

Open each tab and sew on the crease line through the tab and zipper, ensuring the zipper teeth at the open end are aligned together, backstitching at the center through the zipper teeth, to tack the zipper ends in place for extra strength. Repeat on opposite end, ensuring tab placement as shown in Diagram 1.

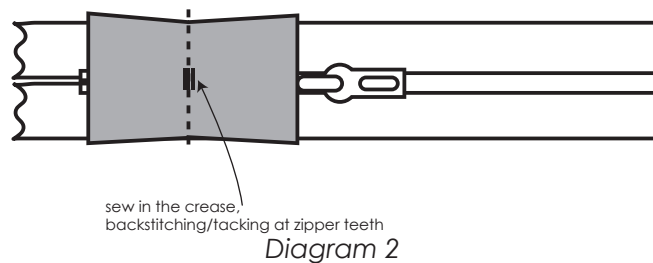

Trim off excess zipper, leaving 1/4" in the seam allowance on either end. Entire zipper including fabric tabs will now measure 12-1/2" long.

Make the Pouch

Place zipper face down/RST along top edge of one Zipper Pouch (Fabric F) piece, aligning as shown.

Place one Pouch Lining piece (Fabric C) RST with the Zipper Pouch piece, aligning all raw edges and sandwiching zipper between layers. Pin in place then stitch using a zipper foot through all layers, sewing close to zipper teeth (approx 3/8" seam allowance).

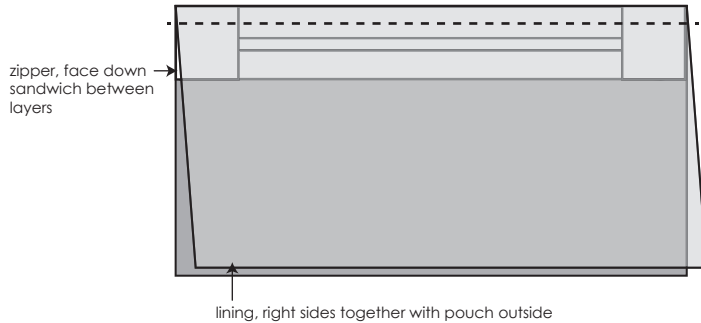

Diagram 3

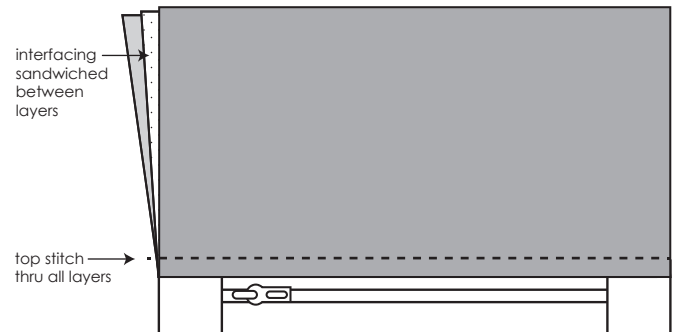

Diagram 4

Open and press. Insert interfacing between the outside and lining layers, aligned with the zipper seam stitching line. Fold the layers back in place, enclosing the interfacing between the layers.

Topstitch along edge of seam through all layers and catching the interfacing from the front outside. Repeat for opposite side of the zipper tape.

Fold pouch so the zipper is on the top outside edge, lining is RST on the inside, aligning all raw edges on sides and bottom. Baste along raw edges with a scant 1/4" seam, closing together sides and bottom edges. Note: Raw edges will be showing on the outside. Trim to 12-1/2" wide, if needed.

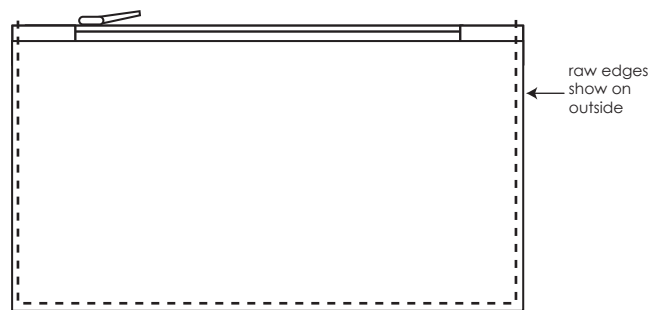

Diagram 5

Set aside.

Make the Inside and Outside Pockets

Place one Outside Pocket piece wrong sides together with one outside pocket interfacing piece, aligning one long edge (becoming the top edge). Note that the interfacing will be 1/2" shorter on each short side than the fabric. Center the interfacing piece with 1/2" fabric allowance showing on each short side.

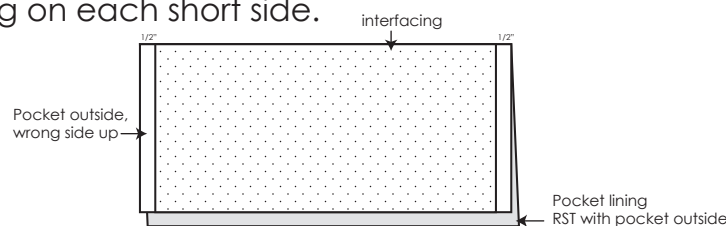

Diagram 6

Place one Pocket Lining piece right sides together with the Outside Pocket piece, aligning along the top edge, and matching side raw edges. Note that the lining will be longer and overhang the bottom edge of the outside and interfacing pocket pieces.

Stitch along the top edge with a 1/2" seam allowance.

Re-align the remaining long edges of the fabric and interfacing so they match along the bottom and side edges. The excess lining will fold up. Stitch the long bottom edge with a 1/4" seam allowance.

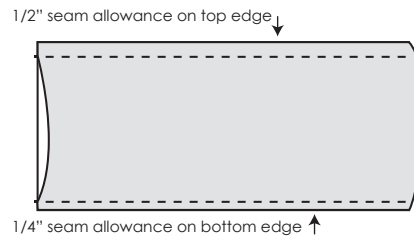

Diagram 7

Turn right sides out and press, noting that the top pocket edge will have 1/2" of lining fabric showing along the outside top as contrast.

Turn in pocket 1/2" side hems to inside on each end, enclosing the raw edges inside the pocket lining and outside layers, giving a finished edge on both the inside and outside of the pocket, and press.

Tip- use a dab of basting glue to hold edges in place inside!

Edgestitch along the edge of the contrast on the pocket top edge.

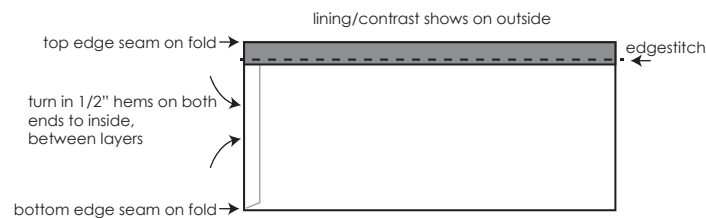

Diagram 8

Finished pocket will measure 12"x 5-1/4".

Repeat above steps to complete the remaining pockets for the inside and the outside of the tote.

Set aside.

Make the Tote Body - Outside

Take one Tote Body Outside piece and one Tote Body Interfacing piece and place wrong sides together, aligning all raw edges. Use spray basting or pin layers together to hold in place.

Quilt as desired.

Trim to 22-1/2" x 12-1/2"

Make two.

Attach the Outside and Inside Pockets

On one Tote Body Outside piece, on the outside, measure and make a mark at 5" up from the bottom edge and centered along the longest side at 11-1/4". On one outside pocket, measure and make a mark centered along the longest side, 6" from each side, along the bottom edge.

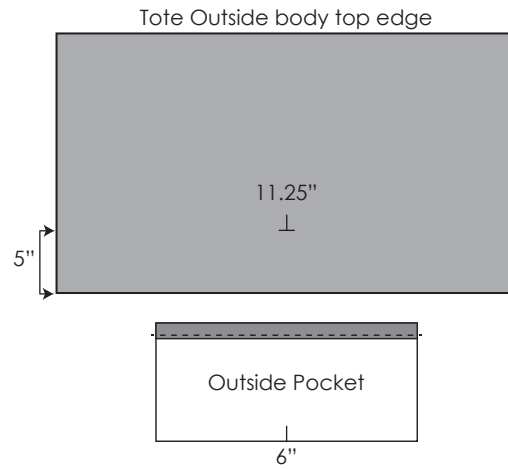

Diagram 9

Position the pocket so the center marks match, and pocket is straight and aligned at 5" from the bottom edge. Pin in place.

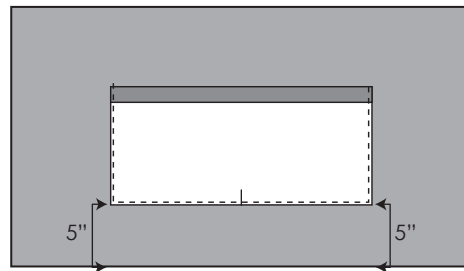

Diagram 10

Edgestitch along sides and bottom of pocket, backstitching at start and end to secure the seam and hold the pocket in place.

Outside Pockets only:

Measure and mark vertical pocket compartment dividing stitching lines as shown at 5" in from the right side and 4" in from the left side. Stitch, backstitching at both ends to secure.

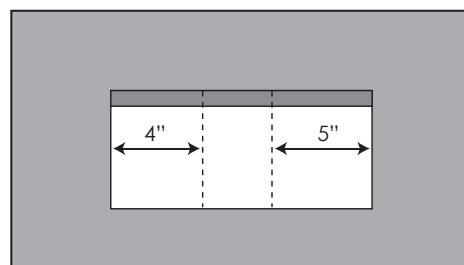

Diagram 11

Inside pockets only:

On one pocket: Measure and mark vertical a pocket compartment dividing stitching line as shown at 6" in from both sides at the center, and stitch, backstitching at both ends to secure.

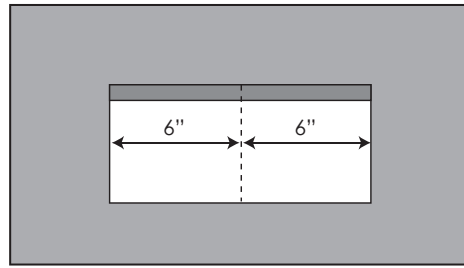

Diagram 12

Leave other pocket open with no additional stitching/dividing lines.

Repeat assembly as above for remaining outside tote piece.

Repeat assembly as above for the lining pieces and inside pockets. See note about additional stitching lines as above, Diagram 12. Set aside.

Tote Lining - Attach Zipper Pouch Divider and Box Corners

Mark and cut the tote lining's boxed corners by measuring in 5" from the side and bottom edges, and cut, removing the corner pieces as shown, on both pieces.

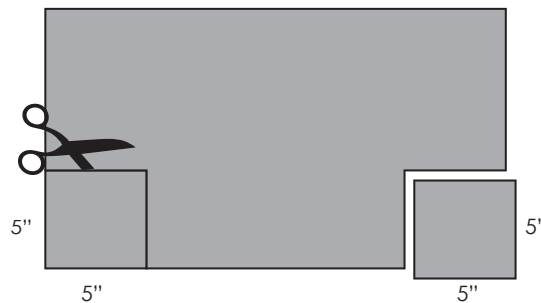

Diagram 13

Attach the zipper pouch and assemble tote lining

With one lining piece right side up, position the zipper pouch so the side seams match and the bottom edge of the pouch is aligned with the top of the 5" corner cut you just cut away. Place the remaining lining piece on top, lining pieces right sides together, sandwiching the pouch between the lining layers.

Stitch from the top edge down toward the bottom, leaving the last 1/4" open and unstitched.

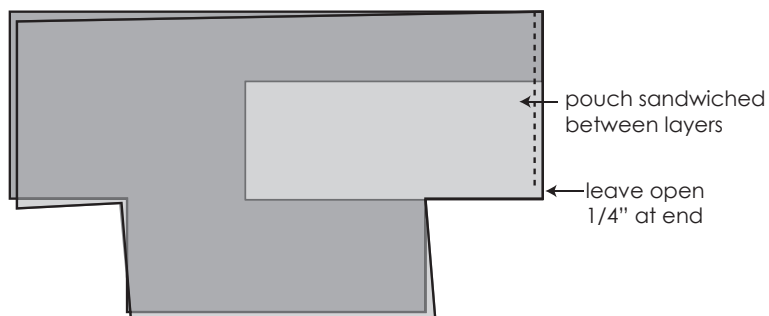

Diagram 14

Repeat this step on the opposite side of the lining, so both side seams are now sewn. Note that the lining is wider than the pouch so it will fold behind.

Realign the lining fabric and pouch so the bottom of the lining pieces and the bottom edge of the pouch are aligned, folding back the unsewn 1/4" seam allowance at the bottom edge of the lining, so it is not included or caught in the seam, and sew across the bottom edge only, through all layers.

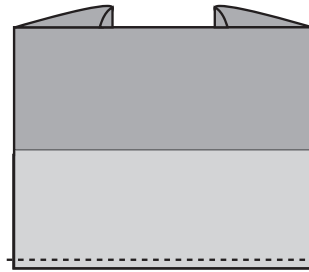

Diagram 15

Box the Corners

Open out the lining, press open the seam allowances and match the bottom seam to the side seam. Sew the bottom seam in two parts: working from one outer corner to the center seam, then flip the piece and sew from the opposite corner to the center, with a 1/4" seam.

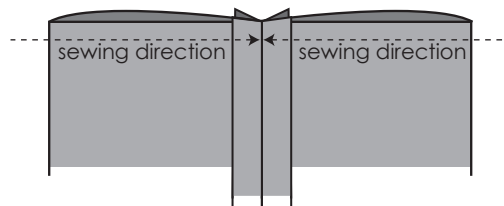

Diagram 16

Repeat on opposite side.
Set aside.

Tote Outside Body, Assemble and Box Corners

Repeat the same process to box the corners of the Tote Outside, sewing side seams first (but sew edge to edge, not necessary to leave 1/4" open at bottom), then sew bottom seam, then box the corners.

Secure Lining to Tote Outside

With the tote outside body and the tote lining pieces both wrong sides facing out, align the bottom edges and bottom/side seam boxed corner seams. Stitch just outside of the boxed corner seam on each end, attaching the lining and tote body pieces together.

Note: This may be awkward to sew, and the seam does not have to be pretty. It just needs to hold the pieces together.

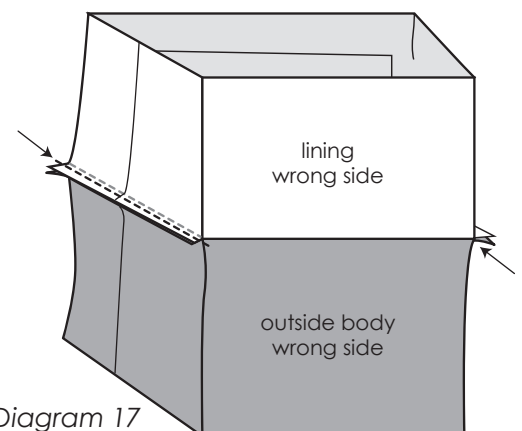

Diagram 17

Turn the bag right side out so lining is on the inside, and the wrong sides on the tote outside and lining are together.

Pin in place, matching top raw edges and side seams, and baste around entire top edge of tote at a scant 1/4".

To secure the pouch and lining together with the tote outside, tack either by hand or machine, just above the top of the zipper pouch, sewing through all layers and ensuring that all seams are aligned.

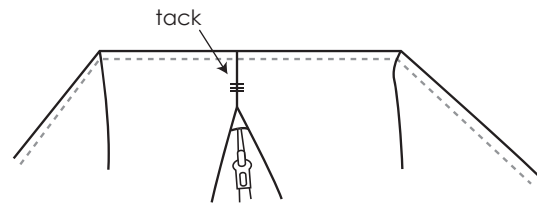

Diagram 18

Set aside.

Make and Attach Tote Handles

With one handle fabric piece, fold lengthwise with wrong sides together, and press, making a crease along the length in the center.

Open the piece out and fold the long raw edges in to meet the crease on each side, and press.

Open one long folded edge and insert one piece of handle interfacing inside the folded layers, then refold in place, enclosing the interfacing and raw edges inside.

Edgestitch along both long outer edges, then stitch once down the center of the handle. Repeat to make two.

On the outside of the tote body, measure and make a mark at the center top edge, then make marks 2" from either side of the center mark.

Align the inner edge of the handles with the 2" marks as shown, pin, then baste in place. Repeat for both handles.

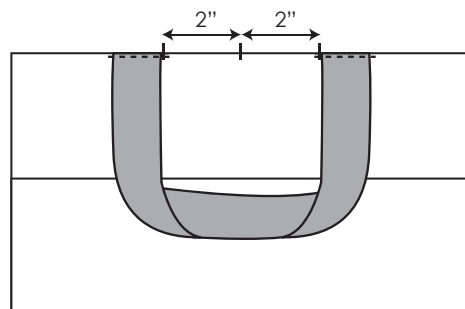

Diagram 19

Finishing

Binding

Sew the two binding strips together on one shortend, making one long, continuous strip. Fold in half lengthwise and press, creating the binding for the top edge of the tote.

Starting at one side seam of the tote, leave a 6" tail, and pin the binding to the top outside edge of the tote body, raw edged aligned, leaving approximately 6" open, without binding pinned in place, at the end. Stitch between start and end pins, leaving the remaining 6" free.

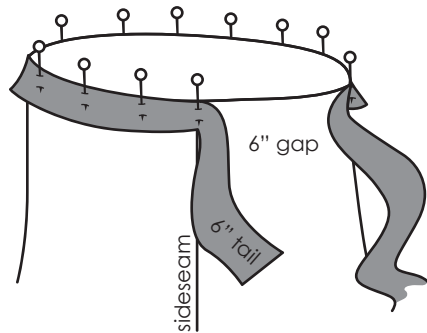

Diagram 20

Arrange the tote so the outside at the side seam is facing you. Bring both tails of the binding to the middle of the unsewn gap, aligning raw edges along the top edge, and fold them back, so the creases meet in the middle.

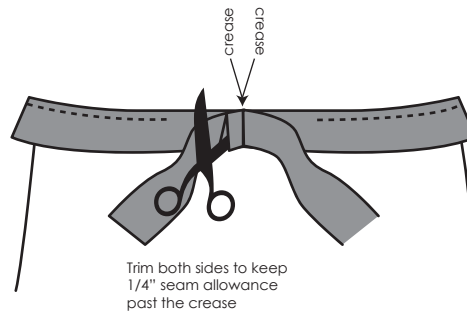

Diagram 21

Trim off excess binding, leaving a 1/4" seam allowance on both ends of the binding, open the ends and with right sides together, stitch the ends together. Align the remaining binding with the top edge of the tote and stitch in place, completing the seam and attaching the rest of the binding.

Turn the binding to the inside of the tote and hand-stitch in place, enclosing the top raw edge. Press well.

Your sewing caddy is now complete!